

Analysis and Evaluation the maximum power point Tracking efficiency of photovoltaic With different DC-DC converter topologies for Photovoltaic Application

MOUHOU BIRANE^{1,2} CHERIF LARBES² ALI CHEKNANE¹

¹ *Laboratoire des Semi-conducteurs et Matériaux Fonctionnels, Université Amar Telidji de Laghouat, BP37G, Bd des Martyrs. Laghouat 03000, Algeria.*

² *Laboratoire Dispositifs de Communication et de Conversion Photovoltaïque, Ecole Nationale Polytechnique Alger, Algeria. 10, Avenue Hassen Badi El Harrach BP 182, Alger, 16200, Algeria.*
Email: m.birane@lagh-univ.dz.

Abstract: In this paper, we present a conduct a study, analysis and evaluation the maximum power point Tracking efficiency of photovoltaic with different DC-DC converter topologies for Photovoltaic Application. Three basic topologies of DC/DC converters with resistive load connected to photovoltaic modules. The objective of this paper is to show the way that photovoltaic converter topologies has made from centralized converter to distributed power system. This article demonstrates that there is a limitation in the system's performance according to the Differences' topologies of converter used. Conventionally, MPPT controller and Boost converter are utilized for each solar panel or channel in this series and parallel architecture connection, which results cost increase. In this paper, different photovoltaic converter topologies are analyzed, the purpose of Solution PV is to design and optimize architectures of the energy conversion chain, monitoring, and control strategies from the PV module to the utility-grid in order to increase reliability of installations pointing out the advantages and drawbacks for each of them. Only one which allows the follow-up of the PV module maximum power point regardless of temperature irradiance, the connection of a boost DC/DC converter in a photovoltaic facility to the panel output could be a good practice to improve performance.

Keywords: Photovoltaic Generator, Maximum Power Point Tracker MPPT, performance, power, DC-DC Converters. Introduction .

I. INTRODUCTION

Renewable sources of energy acquire growing importance due to its enormous consumption and exhaustion of fossil fuel. Renewable energy is abundant, free, sustainable, and clean and can be harnessed from different sources in the form of wind, solar, tidal, hydro, and geothermal and biomass [1]. Energy supplied by the sun in one hour is equal to the amount of energy required by the human in one year [2]. Photovoltaic energy system has gained wide popularity in the past decade as one of the renewable energy sources due to the possibility of depletion of conventional energy sources and its high cost as well as its negative effects on the environment. The choice will involve a bigger or smaller energy production and efficiency as well as an importance difference in the cost. For this reason, it

is important to know different types of architecture in order to choose the correct PV architecture for each PV installation [4] [3].

Solar energy could be one of the significant sources as an alternative energy for the future. In regard to endless importance of solar energy, it is worth saying that photovoltaic energy is a best prospective solution for energy crisis [4]

The architecture of the power converter is important in a PV system. This structure determines the main characteristics of the photovoltaic installation, as the amount the PV modules need for the PV system and its type of connection. The effect of the partial shadowing or mismatch between PV modules in the energy production will also depends on the type of the architecture. Nevertheless, the price and cost of the PV also depends on the choice of the architecture. [5].

The inverters must guarantee that the PV module(s) is operated at the MPP, which is the operating condition where the most energy is captured. This is accomplished with an MPP tracker (MPPT). It also involves the ripple at the terminals of the PV module(s) being sufficiently small, in order to operate around the MPP without too much fluctuation.

The past technology, illustrated in Fig. 3(a), was based on centralized inverters that interfaced a large number of PV modules to the grid [6]. The PV modules were divided into series connections (called a string), each generating a sufficiently high voltage to avoid further amplification. These series connections were then connected in parallel, through string diodes, in order to reach high power levels. This centralized inverter includes some severe limitations, such as high-voltage dc cables between the PV modules and the inverter, power losses due to a centralized MPPT, mismatch losses between the PV modules, losses in the string diodes, and a nonflexible design where the benefits of mass

production could not be reached. The grid-connected stage was usually line commutated by means of thyristors, involving many current harmonics and poor power quality.

The present technology consists of the string inverters and the ac module [7]. The string inverter, shown in Fig. 3(b), is a reduced version of the centralized inverter, where a single string of PV modules is connected to the inverter. The input voltage may be high enough to avoid voltage amplification. The possibility of using fewer PV modules in series also exists, if a dc–dc converter or

line-frequency transformer is used for voltage amplification. There are no losses associated with string diodes and separate MPPTs can be applied to each string. This increases the overall efficiency compared to the centralized inverter, and reduces the price, due to mass production.

The multi-string inverter depicted in Fig. 3(c) is the further development of the string inverter, where several strings are interfaced with their own dc–dc converter to a common dc–ac inverter, [8].

II-MATHEMATICAL MODELING OF THE PV MODULES

A solar cell constitutes the basic unit of a PV generator which, in turn, is the main component of a solar generator. The electrical analysis of the PV cell includes a source which is the sun and unique equivalent electrical circuit which includes diode and series and parallel resistances.

A solar cell equivalent electrical circuit can be represented by a one-diode model as shown in fig.2:

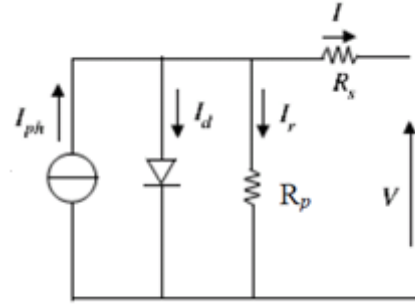

Figure. 2: General model of PV cell in a single diode model

Solar cell can be represented by photocurrent source, a diode, a parallel resistor also called shunt resistor (R_p) expressing a leakage current and a series resistor (R_s) describing internal resistance to the current flow.

The PV cell electrical characteristic under solar irradiance (G) is given in terms of PV cell output current (I) and PV cell voltage (V). Refers to figure 2 and based on the first law of Kirchhoff, the basic equations which describing electrical characteristics of the PV cell model

The relation between the array terminal current and voltage is the following:

$$I = I_{ph} - I_D - \frac{V + I R_s}{R_p} \quad (1)$$

$$I = I_{ph} - I_0 \left[e^{\frac{q(V + I R_s)}{nKT}} - 1 \right] - \frac{V + I R_s}{R_p} \quad (2)$$

$$I_{ph} = I_{SC} \frac{\phi}{1000} \quad (3)$$

Where: I and V are the output current and output voltage of the photovoltaic cell, I_{ph} is the generated photo-current, I_0 is the diode's reverse saturation current, n the diode ideality factor, R_s and R_p the series and parallel resistance (respectively), and T is the absolute temperature in Kelvin. The equation also contains the elementary charge constant q ($1,602 \cdot 10^{-19} \text{C}$) and the Boltzmann constant k ($1,380 \cdot 10^{-23} \text{J/K}$).

A solar cell is the building block of a solar panel. A photovoltaic module is formed by connecting many solar cells

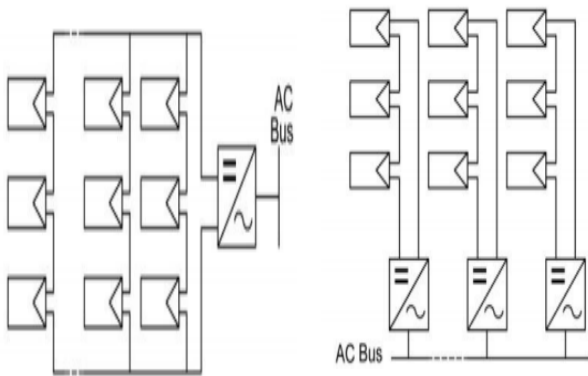

a) Centralize technology b) String technology

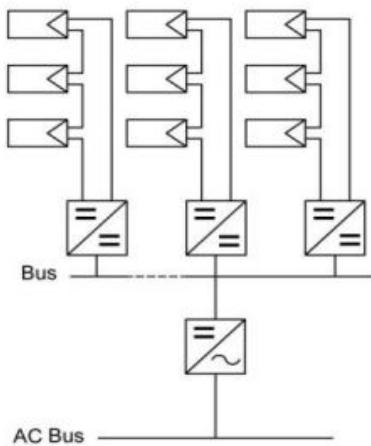

c) Multi-string technology

Figure. 1: Differences' architecture of PV systems.

in series (N_s) and parallel (N_p). The output power available from the PV generator is given by:

$$P_{pv} = N_s * V_{pv} * N_p * I_{pv}$$

We consider N_p as the number of cells connected in parallel and N_s as the number of cells connected in series, the relationship between the output current and voltage is given by [9]

$$I_{ph_final} = N_p I_{ph}$$

$$I_0_final = N_p I_0$$

$$n_final = N_s n$$

$$R_s_final = \frac{N_s}{N_p} R_s$$

$$I = N_p I_{ph} - N_p I_0 \left[e^{\frac{q}{nKT} \left(\frac{V}{N_s} + \frac{IR_s}{N_p} \right)} - 1 \right] - \frac{N_p}{R_p} \left(\frac{V}{N_s} + \frac{IR_s}{N_p} \right) \quad (4)$$

The equivalent circuit for the solar module arranged in N_p parallel and N_s series is shown in Figure 3.

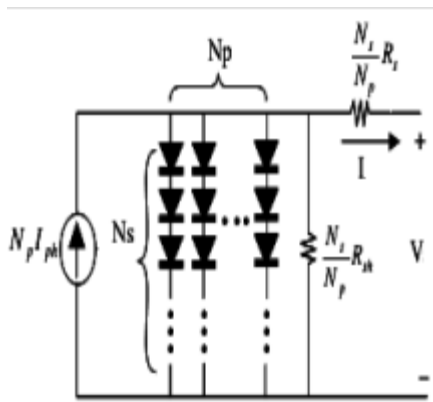

Figure. 3: Equivalent circuit model of generalized PV .

III. ANALYSIS OF DC / DC CONVERTER

In this paper we describe and analyze a new way to measure characteristic curve by using DC-DC converters. The switching power converter DC-DC are widely used in photovoltaic systems to transform DC power between a voltage and another, and are also used in maximum power point tracker (MPPT).

The goal of the DC optimizer is to extract the maximum power possible from the PVG, placing the MPPT in a distributed way.

The DC-DC converters concerned in this study are step-up voltage converters known as Boost converters. The electrical schema of the boost converter is reminded in the fig. (4).

Nowadays, there are two widespread and cost-effective technologies suitable for the implementation of the proposed converter switches: MOSFET and IGBTs because both technologies are available for the intended operation voltage, current and frequency.

In this study concerned of Si-IGBT (Insulated Gate Bipolar Transistor) switched mode converter able to produce a dc output voltage that is greater in magnitude than the dc input voltage [11].

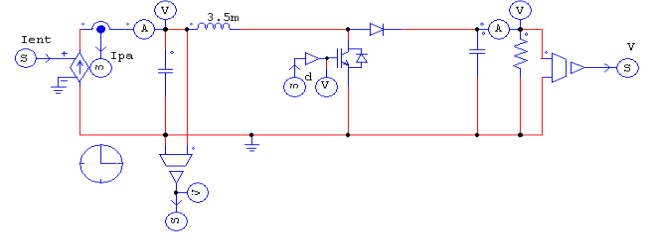

Figure.4. Electric structure of the boost power converter

The boost converter is one of the simplest DC-DC converters. In a DC transformer the relationship of transformation can be controlled electronically by changing the duty cycle of the converter in the range [0, 1].

The relationships used for the design are the conventional relationship between the output voltage, the input signal and the duty ratio [10]:

$$V_{OUT} = \frac{1}{1-\alpha} V_{in}$$

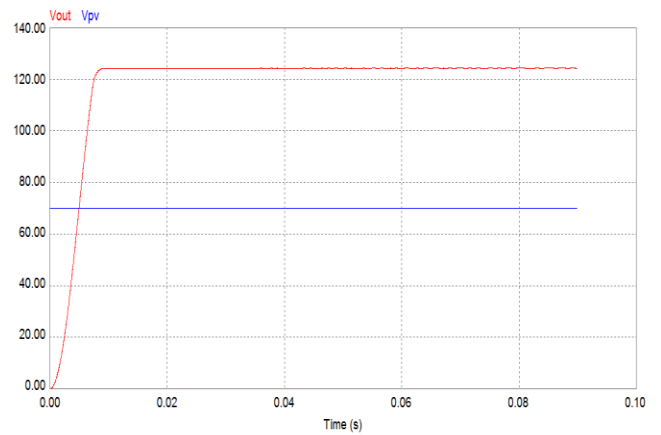

Figure.5. Input and output voltage of the boost power converter

Study continuous state: Replacing derived signals with zeros, we can replace the converter signals by their average values, and it will simplify the system of equations:

$$\begin{cases} I_L = I_i \\ I_o = (1-\alpha)I_L \\ V_i = (1-\alpha)V_o + r_L \cdot I_L \end{cases} \quad (5)$$

Conversion and performance report:

Using the relations (5), one can calculate the conversion ratio

$$\begin{aligned} M(\alpha) &= \frac{V_o}{V_i} = \frac{1}{(1-\alpha) + \frac{r_L I_L}{V_o}} = \frac{1}{1 + \frac{r_L I_o}{(1-\alpha)^2 V_o}} \frac{1}{1-\alpha} \\ &= \frac{1}{1 + \frac{r_L}{(1-\alpha)^2 Z}} \frac{1}{1-\alpha} = \eta \frac{1}{1-\alpha} \end{aligned}$$

Where
$$\eta = \frac{1}{1 + \frac{r_L}{(1-\alpha)^2 Z}}$$

Represents the efficiency of the converter

Note that the η performance not only depends on the complex load Z of the converter and parasitic resistances of the components, but it also depends on the cyclic α report. Thus it is recommended that the Boost provides good performance, not to exceed duty cycles higher α to a certain value, determined by the quality of the inductance and the filler used.

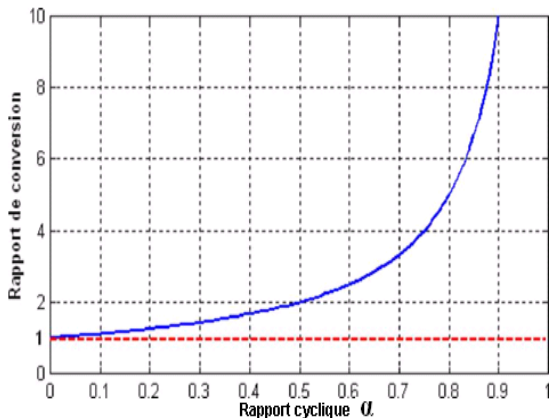

Figure.6. Allure of the conversion ratio as a function of duty cycle α .

The interconnecting different structures, new tasks that only with one converter cannot be achieved are reached.

For instance, Many type of association can be envisaged, the series and parallel connection of converter involve a major power transfer capability. The series connections increase the voltage. The parallel connections are used to increase the current.

A. Series-connected DC-DC converter control strategy

In this paper the series-connected DC-DC converter system topology is composed of Boost converters that are assembled in strings. Each panel is then connected to a single DC-DC converter, as presented below figure (7) .

In series connected ports, the voltages are added. Thus, higher voltage can be achieved in the output port, and therefore, this output port can be directly connected to a grid-tied inverter, assuring an adequate voltage level for its inversion and grid connection. Nevertheless, as all the output must have the same current level, the system often presents a big instability and its control a high complexity to resolve it, representing the biggest drawback of this kind of connection [3].

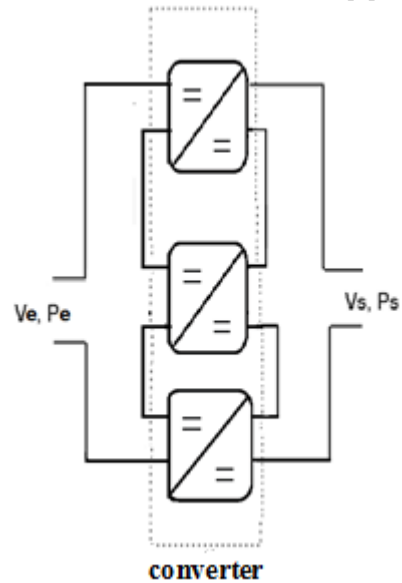

Figure.7. Series connection of converter

The number of series-connected converters is directly linked to the required Boost voltage ratio in order to maintain a decent DC bus voltage. In normal operation, they participate equally to the string voltage. Hence, the output voltage of each Boost converter is VDC/N . Consequently, the more converters are placed per string; the lower is the voltage ratio for each converter. Considering normal operation of the PV system, the Boost converters can fulfill both MPPT and maintain a sufficient DC bus voltage. However, in degraded mode operation (ie. Partially shaded strings) the output voltage of the Boost converters may require an additional control strategy in order to limit over-voltage [12].

B. Parallel connected DC-DC converter control strategy

The parallelization of power converters is one of the simplest forms of connecting power structures. For this reason, it is one of the most used interconnection techniques. Apart from the simplicity of control, the parallel connection of converters allows the connection of almost all the converters structures. Either DC-DC converters or inverters can be connected in parallel. Nevertheless, a successful selection of the paralleling scheme requires a firm understanding of merits and limitations of different paralleling schemes. The paralleling scheme must be selected by taking the complexity, cost, modularity, and reliability into consideration. Various interactions among converters modules must be incorporated into the control design and system integration to ensure stability, reliability and good dynamic performance [3]

Parallel connection capable, with a homogeneous distribution of power, reduce stress endured by the semiconductor and thus improve the reliability, robustness and lifetime of the conversion stage. This structure also provides a degree of freedom in terms of flexibility and modularity, with respect to a conventional converter [15].

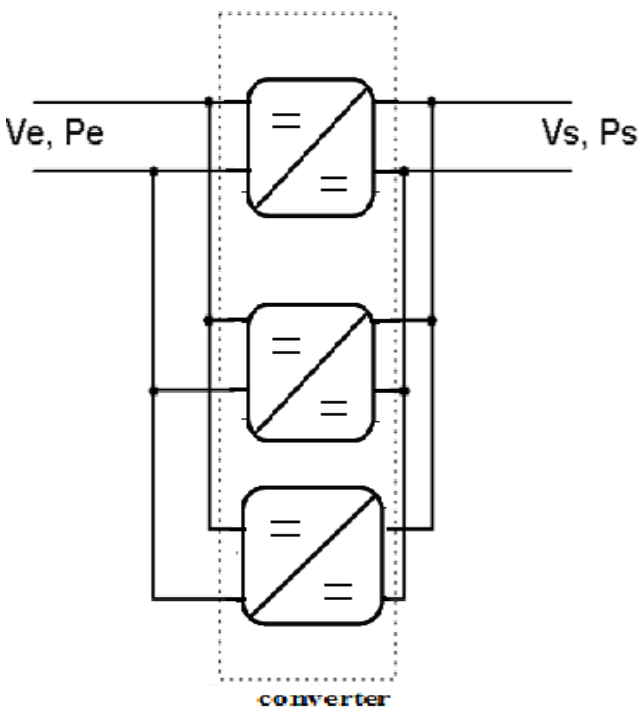

Figure.7. Parallels connection of converter

The major advantage of these structures is the reduction of the thermal and electric stress in the components. As the charge is divided, a bigger power charge can be transferred without an increase in the power component stress. In this way, the system gains in robustness and in reliability.

IV. DC-DC CONVERTER CONTROL

The DC-DC converter control strategy consists in extracting the maximum power of the PV array by determining the optimal input voltage reference. The voltage reference is set by using a MPPT algorithm which tracks the evolution of the PV array power in order to find the optimal voltage reference. [12].

The use of DC optimizers to extract the maximum photovoltaic energy is more widely used. These structures are placed next to the PV module, and they extract the maximum energy from the PV module in a distributed way. According to photovoltaic use forecast studies. [13].

The last proposed architecture to optimize power transfer, is to use a matching stage DC / DC controller with MPPT. This management architecture corresponds to a discrete architecture. In fact, each given field will have its own floor of adaptation to exploit the power available at the terminals of PV. Thus, approaching as close to the source of production, it is hoped to produce maximum power. The diagram in Fig.5 thus shows the principle of power control.

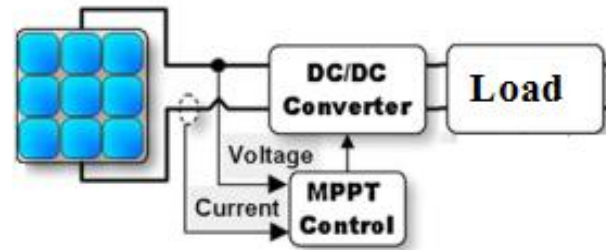

Figure.8. Simplest electrical scheme block of a typical power conversion chain.

The main goal of a MPPT control is to automatically find at each time the V_{OPT} and I_{OPT} of a PV array and then to allow it to operate at its PMPP under given temperature and irradiance. Best MPPT control algorithms have to be fast, stable, robust, and efficient. MPPT methods, commonly used in widespread applications, are currently reported in the literature [14].

V. MAXIMUM POWER POINT TRACKING (MPPT)

A. Maximum Power Point Tracking (MPPT)

MPPT algorithm of the proposed system is based on the direct adjustment of the duty cycle of DC/DC converter which is resulted from the sequential comparison of the output power of solar modules as well as the difference of output powers in two consecutive moments [16]. The main goal of a MPPT control is to automatically find at each time the V_{OPT} and I_{OPT} of a PV array and then to allow it to operate at its PMPP under given temperature and irradiance. Best MPPT control algorithms have to be fast, stable, robust, and efficient. MPPT

methods, commonly used in widespread applications, are currently reported in the literature [14].

The main goal of a MPPT control is to automatically find at each time the V_{OPT} and I_{OPT} of a PV array and then to allow it to operate at its PMPP under given temperature and irradiance. Best MPPT control algorithms have to be fast, stable, robust, and efficient. MPPT methods, commonly used in widespread applications, are currently reported in the literature [14].

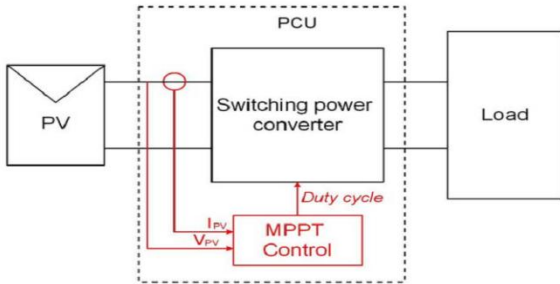

Figure.9. Simplest electrical scheme block of a typical power conversion chain.

The current and voltage measurements are important parts in the MPPT controls, since they affect the accuracy and the efficiency of the controls. The place of each sensor can be done at the input and/or output ports of the power converter stage associated with the PVG.

VI. SIMULATION RESULTANTS AND DISCUSSION:

In the first topology we have used two PV panels mounted in series and two in parallel, and one converter. The converter is controlled with an MPPT controller.

The simulations were done using PSIM software for electrical circuits.

A. Simulation of a central grid connected photovoltaic

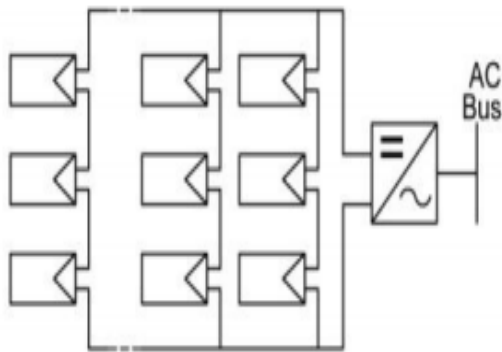

Figure.10. Central converter onfiguration

$$P_{in} = 72 \text{ w}, P_{out} = 56 \text{ w}, \eta = 0.77$$

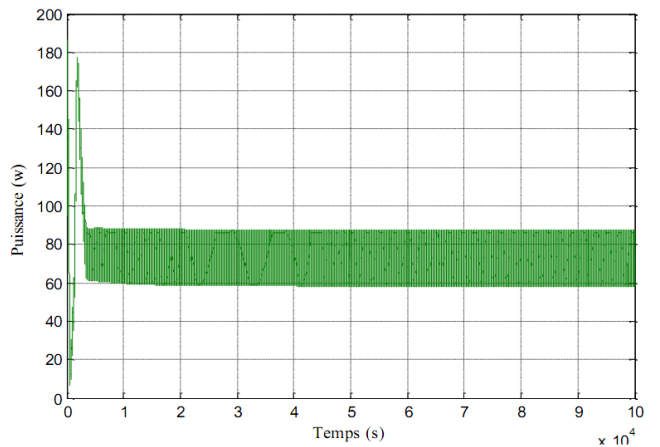
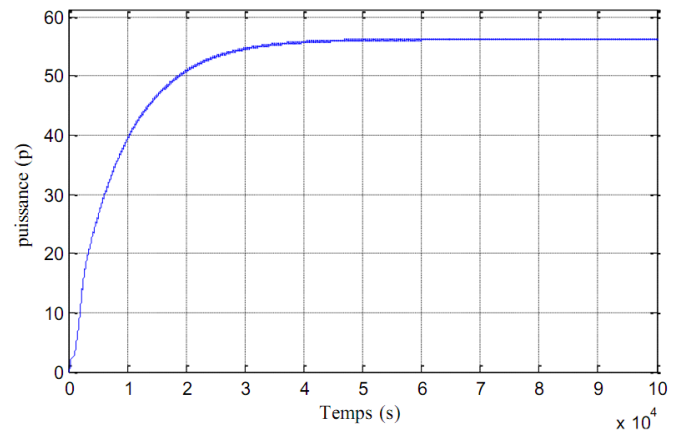
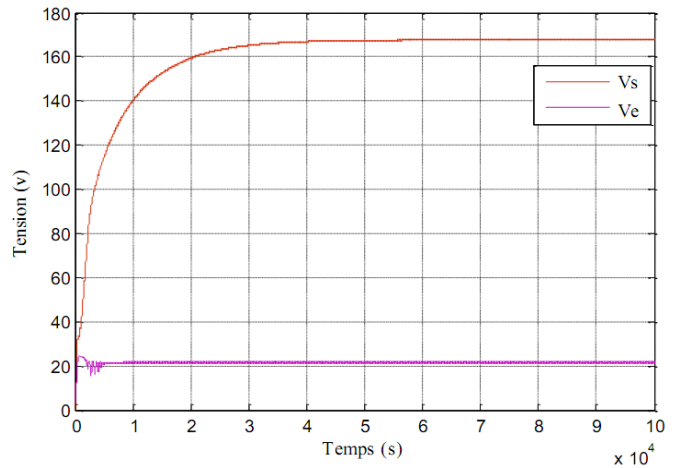

Figure. 11. Simulation results of central grid connected photovoltaic.

B .Simulation of a string grid connected photovoltaic

1/ The grid connected are connected in series

$$P_{in} = 180 \text{ w}, P_{out} = 142 \text{ w}, \eta = 0.79$$

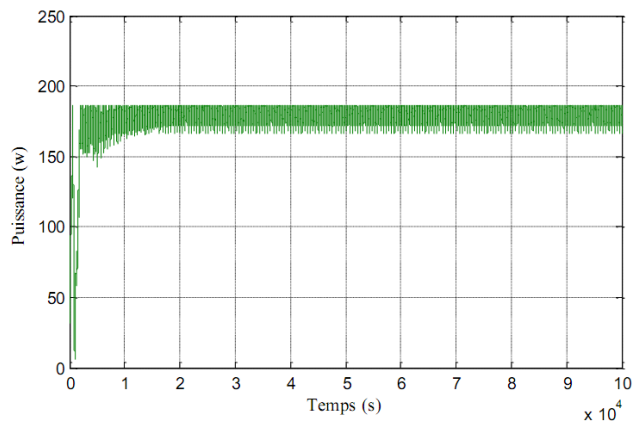
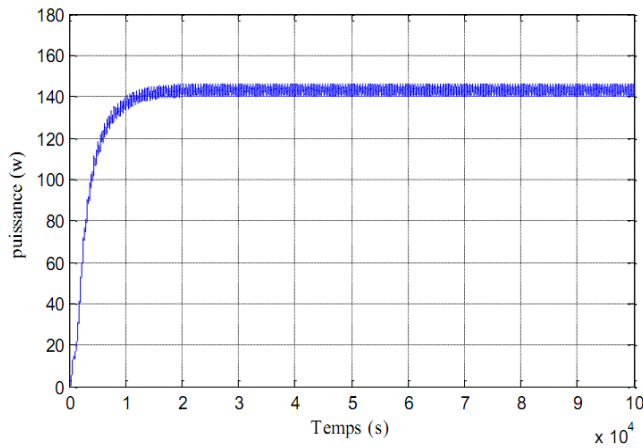
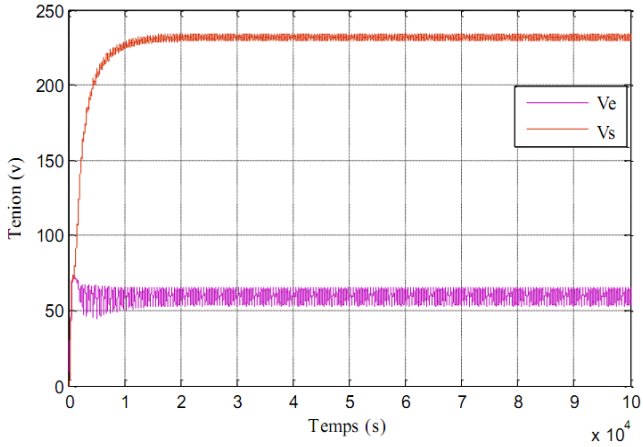

Figure .12. Simulation results of grid connected in series.

2 / The grid connected are connected in parallel

$$P_{in} = 173, P_{out} = 141, \eta = 0.82$$

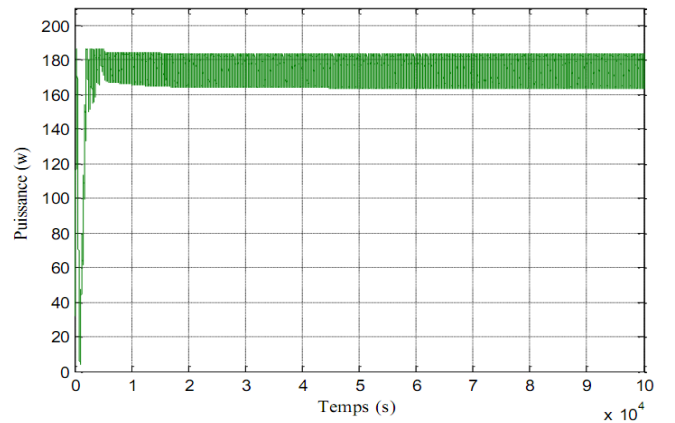
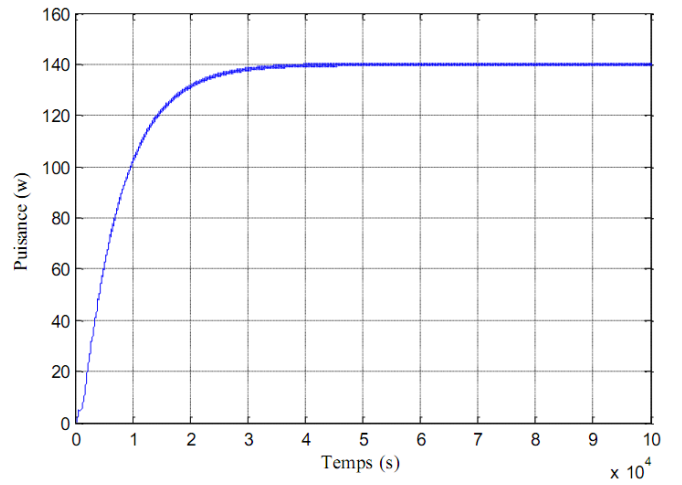
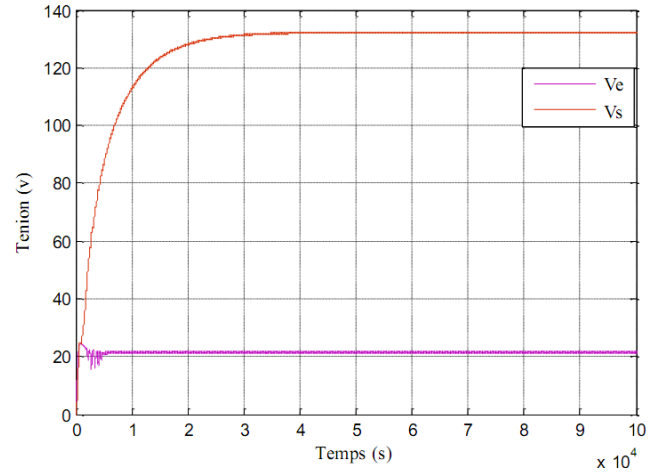

Figure .13. Simulation results of grid connected in parallel

That the efficiency η increases rapidly with the power to reach a maximum yield of 77 % - 82 %.

- $\eta = 0.77$ in central grid connected photovoltaic.
- In string grid connected photovoltaic
 - ❖ $\eta = 0.79$ in series.
 - ❖ $\eta = 0.82$ in parallel.

VII .CONCLUSION

In this paper to compare the matching efficiencies of three different topologies for connecting a converter The Three topologies were a direct PV module-battery connection ,a boost converter maximum power point tracker (MPPT),The boost converter is shown to have a slight advantage over the buck, Particularly at low light levels ,since it can always track The maximum power point .The direct connection is always shown to be inferior.

The output power delivered by a PV module can be maximized using MPPT control system. It consists of a power conditioner to interface the PV output to the load, and a control unit, which drives the power conditioner for extracting the maximum power from a PV array. In this paper, a MPPT system has been proposed and tested by simulations in MATLAB's Simulink toolbox, for simulation of PV-generator and PSIM software for electrical circuits BOOST converter simulation while modeling BOOST converter is provided by PSIM. It follows the irradiance and the temperature level change rapidly and tracks the MPPT.

Hence, in this dissertation, we became interested to increase the efficiency of PV system, we have applied perturb and observe maximum power point tracker for different topologies in the aim of extracting the maximum DC output power using the simplest PV system architecture.

However, in case more strings operate in parallel on the same inverter the yield might be even more considering the whole array could be operated in a single maximum power point only.

Finally, this work can be extended in several directions including: Integrates the system with other MPPT methods and comparing their results. Real implementation of these topologies is also a challenge that can increase the efficiency of real PV systems and their output power.

REFERENCES

- [1] Frank kreith, D. Yogi Goswami, 2007, —Handbook of Energy Efficiency and Renewable EnergyI, CRC Press, 2007.
- [2] J. R. Messenger and J. Ventre, "Photovoltaic Systems Engineering", Second Edition, CRC PRESS, 2005. .
- [3] Alona, B.A "New Optimized Electrical Architectures of Photovoltaic Generators with High Conversion Efficiency" Doctoral Thesis, University of Toulouse3 Paul Sabatier (UT3PaulSabatier), France 2013.
- [4] MBOUMBOUE Edouard.and Donatien NJOMO, "Mathematical Modeling and Digital Simulation of PV Solar Panel using MATLAB Software " International Journal of Emerging Technology and Advanced Engineering (ISSN 2250-2459, ISO 9001:2008 Certified Journal, Volume 3, Issue 9, September 2013).
- [5] Alona, B.A "New Optimized Electrical Architectures of Photovoltaic Generators with High Conversion Efficiency" Doctoral Thesis, University of Toulouse3 Paul Sabatier (UT3PaulSabatier), France 2013.
- [6] M. Calais, J. Myrzik, T. Spooner, and V. G. Agelidis, "Inverters for single-phase grid connected photovoltaic systems—An overview," in Proc. IEEE PESC'02, vol. 2, 2002, pp. 1995–2000.
- [7] M. Meinhardt and G. Cramer, "Past, present and future of grid connected photovoltaic- and hybrid-power-systems," in Proc. IEEE-PES SummerMeeting, vol. 2, 2000, pp. 1283–1288.
- [8] M. Meinhardt and G. Cramer, "Past, present and future of grid connected photovoltaic- and hybrid-power-systems," in Proc. IEEE-PES SummerMeeting, vol. 2, 2000, pp. 1283–1288.
- [9] Dani Rusirawan, (2012), —Energetic modeling of photovoltaic modules in grid-connected systems ||, Ph.D Dissertation, SZENT ISTVÁN UNIVERSITY, Gödöllő-Hungary, 2012.
- [10] Birane.M, Larbes C, cheknane A "Topologies modeling efficiency of DC / DC converter for CCM and DCM mode for applications of renewable energy systems". International Conférence on Renewable Energy ICRE 2012 15/16 avril 2012 - Université A. Mira - Bejaia.
- [11] Noman. Rao, Dinesh. Chamund "Calculating power losses in an IGBT Module" AN6156-1 September 2014 LN31943.
- [12] Damien Picault; »Reduction of mismatch losses in grid-connected systems using alternative topologies ". PhD thesis, University of Grenoble Polytechnic Institute of Grenoble, 1er October 2010.
- [13] G. Sheppard; "Energy Efficiency Technology to Take Solar Market by Storm", February, 2011. Available in: www.isuppli.com
- [14] P. Assis Sobreira, M.Gradella Villalva, P.Gomes Barbosa, H.A. Carvalho, J.R. Gazoli, E. Ruppert, A.A. Ferreira; "Comparative analysis of current and maximum voltagecontrolled photovoltaic Maximum Power Point tracking"; Power Electronics Conference , COBEP, Brazil, 2011.
- [15] Pierre PETIT " Optimisation du transfert d'énergie dans les systèmes photovoltaïques" Thèse de doctorat de l'Université de Paul verlaine Metz juillet 2011.
- [16] Marjan Dadras, Meisam Farrokhifar, "A High Performance DC/DC Converter as MPPT for Solar modules," International Journal of Renewable Energy Research, Vol.5, No.3, 2015.